

USER GUIDE

DM Engineering Mic Pro Microphone ON/OFF Lighted Pushbutton Module

Version 1.4

DM Engineering
2174 Chandler St.
Camarillo, CA 91345-4611
805-987-7881 800-249-0487
www.DMEngineering.com

Overview:

The DM Engineering "Mic Pro" module consists of high reliability LED lighted "MIC ON" and "MIC OFF" buttons, enclosure and connecting cables, and when combined with the DM Engineering SLAVE Studio Relay Pack or any other relay pack with required outputs (see below), will upgrade a low cost production mixing board to have the microphone switching features of a professional broadcast console. The "MIC ON" and "MIC OFF" buttons enable and disable the mic channel(s) so the mic level control(s) can be left at the optimum settings. More than one Mic input can be controlled simultaneously. Monitor speaker muting and "ON AIR" or "RECORDING" signs are controlled the SLAVE relay pack. The MIC PRO is attached to the mixing board with the supplied hook and loop fastener system or double sided tape (for a more permanent solution), as shown below.



Operation:

Pressing the "MIC ON" button activates the relay pack in a latched on condition. Pressing the "MIC OFF" button deactivates the relay pack. (Speaker muting, lighting of "Recording" or "On Air" signs and control of any other devices is accomplished by the relay pack. Instructions for speaker muting are given here.)

Relay Pack Required Inputs/Outputs:

Note: The Studio Slave Relay Pack uses a mini-din connection between the Mic Pro and itself, and has all of the necessary voltage inputs and outputs provided and relay contacts available. Other relay packs will require the following:

- 9-12VDC capable of 35ma
- 2 SPDT (form C) sets of available relay contacts, (4 sets if speaker muting is desired)
- Latching On and Off inputs

Installation:

1. Clean the side of the mixing board where the "Mic Pro" and cable anchors are to be located with the supplied alcohol swab.
2. Attach the "Mic Pro" module to the side of the mixing board where desired using either the permanent adhesive squares or the Velcro fasteners.

- Route the control cable along the side of the board and secure with the supplied cable ties and anchors.
3. Remove power from the relay pack and attach the “Mic Pro” control cable to the Studio SLAVE Relay Pack mini-din input connector and skip to step 5.
 4. If you are using another type of relay pack, NOT the DME Studio Slave, cut off the mini-din connector, strip back the cable insulation about 4 inches, strip and tin the ends of the wires and connect the wires as follows:
 - a. Red wire to 9-12VDC
 - b. Black wire to power common
 - c. Green to relay 1 common
 - d. Yellow to relay 1 NO
 - e. Orange to relay 1 NC
 - f. Grey to any input common
 - g. Blue to Latch ON
 - h. White to Latch OFF
 - i. The pink, beige and brown wires are not used and may be cut off.
 5. Attach the supplied Insert control cable to the relay pack as follows:
 - a. Red wire to relay 3 NC (mic preamp output-tip)
 - b. Black wire to relay 3 common (line level input to board-ring)
 - c. Blue wire to relay 3 NO (1K resistor network to shield within cable)

Note: If your board Insert connector is wired differently swap the red and black wires.
 6. Connect the Insert control cable plug to the MIC 1 insert receptacle.
 7. Connect other desired optional Insert control cables to successive relay contact terminals as in step 4 and to their respective insert receptacles.
 8. Connect Left channel monitor speaker muting as follows:
 - a. Connect board Left Control Room or monitor output high to relay 5 NC
 - b. Connect Left Monitor Amp in high to relay 5 common
 - c. Connect one end of a 620-680 ohm resistor to relay 5 NO
 - d. Connect the other end of the resistor to both the Left Control Room or monitor output low and the Monitor Amp in low. This may involve connecting the shields to this connection also. Test for ground loop hum and add or remove the shields accordingly.
 9. Connect the Right channel monitor speaker muting as shown in step 8 to relay 6. Substitute Right for every mention of Left.

The use of the above resistors assures that the Monitor Amplifier is muted and properly terminated during the “Mic On” condition to avoid any speaker noise. The Insert Jack has the proper termination already installed within the cable.

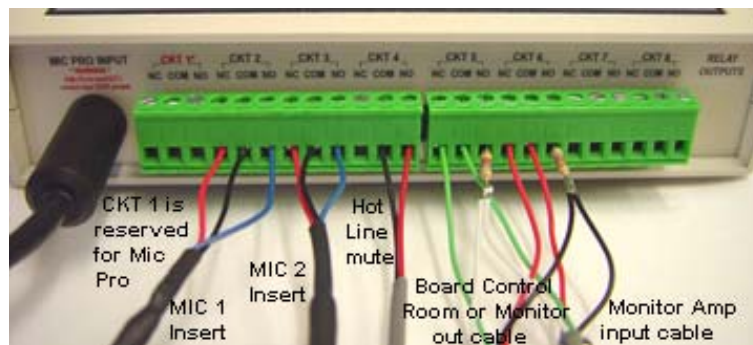

Typical Wiring Connections to the Studio SLAVE Auxiliary Relay pack

Warranty Information:

The DM Engineering Mic Pro is warranted for a period of one year from the date of purchase. This warranty covers materials and workmanship only. Any misapplication, physical or electrical damage from outside sources or by the customer is not covered. The customer must pay shipping costs to the factory, and DME will pay shipping costs to return the warranted equipment to the customer. Any priority shipping costs are to be the responsibility of the customer as ground service is standard. Please contact the factory for an RMA number prior to any returns. Items returned without an RMA may be sent back to the customer unopened.

Technical Support

If you have questions, experience difficulties with the product or require further information please contact DME at: 805-987-7881, toll free 800-249-0487, or E-mail technical support at: info@dmengineering.com, or visit www.DMEngineering.com for the latest User Guide.

Specifications:

Case dimensions: 2.6" wide X 2.6" deep X 1.1" high
Case material and color: Styrene plastic, light grey
Input connection method: 8 ft. black control cable with mini-din 8 connector
DC input requirement: 9-12VDC @ 35ma maximum. (supplied by Relay Pack)
Mounting: Hook and loop fasteners or double sided tape (supplied)
Operating temperature: 32 to 120F
Humidity: 0 to 95% non-condensing
Shipping Weight: 1 lb. (approximate)

Supplied Materials:

"Mic Pro" module with 8 ft. control cable
One 8 ft. insert cable assembly with connector and resistive termination included
Hook and loop fastener materials for removable installation
Double sided adhesive pads for non-removable installation
Alcohol swab
Cable ties and tie anchors (2)
620 or 680 ohm resistors (2) for monitor speaker muting circuit connections
This User guide

Note: Extra Insert Cables may be purchased separately by contacting DM Engineering